



MC4 EVO

USER/INSTALLER MANUAL



EN

V1.0
REV. 05/2022

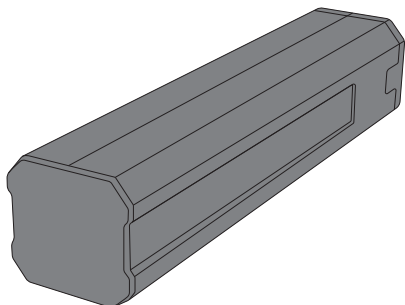

00. CONTENT

INDEX

01. AVISOS DE SEGURANÇA	1B
02. ESQUEMA DE LIGAÇÕES	
DIAGRAMA DE CONEXÕES	4A
03. A CENTRAL	
CARACTERÍSTICAS TÉCNICAS	4B
LEGENDA DOS CONETORES	4B
04. PROGRAMAÇÃO	
INFORMAÇÕES PRÉ-PROGRAMAÇÃO	5A
PROGRAMAÇÃO DE COMANDOS	5B
PROGRAMAÇÃO DE COMANDOS ATRAVÉS DE 1 JÁ PROGRAMADO	6A
APAGAR COMANDOS	7A
ALTERAR DIREÇÃO DO MOTOR	7A

01. SAFETY INSTRUCTIONS

ATTENTION:

	This product is certified in accordance with European Community (EC) safety standards.
RoHS	This product complies with Directive 2011/65/EU of the European Parliament and of the Council, of 8 June 2011, on the restriction of the use of certain hazardous substances in electrical and electronic equipment and with Delegated Directive (EU) 2015/863 from Commission.
	(Applicable in countries with recycling systems). This marking on the product or literature indicates that the product and electronic accessories (eg. Charger, USB cable, electronic material, controls, etc.) should not be disposed of as other household waste at the end of its useful life. To avoid possible harm to the environment or human health resulting from the uncontrolled disposal of waste, separate these items from other types of waste and recycle them responsibly to promote the sustainable reuse of material resources. Home users should contact the dealer where they purchased this product or the National Environment Agency for details on where and how they can take these items for environmentally safe recycling. Business users should contact their vendor and check the terms and conditions of the purchase agreement. This product and its electronic accessories should not be mixed with other commercial waste.
	This marking indicates that the product and electronic accessories (eg. charger, USB cable, electronic material, controls, etc.) are susceptible to electric shock by direct or indirect contact with electricity. Be cautious when handling the product and observe all safety procedures in this manual.

01. SAFETY INSTRUCTIONS

GENERAL WARNINGS

- This manual contains very important safety and usage information, very important. Read all instructions carefully before beginning the installation/usage procedures and keep this manual in a safe place that it can be consulted whenever necessary.
- This product is intended for use only as described in this manual. Any other enforcement or operation that is not mentioned is expressly prohibited, as it may damage the product and put people at risk causing serious injuries.
- This manual is intended firstly for specialized technicians, and does not invalidate the user's responsibility to read the "User Norms" section in order to ensure the correct functioning of the product.
- The installation and repair of this product may be done by qualified and specialized technicians, to assure every procedure are carried out in accordance with applicable rules and norms. Nonprofessional and inexperienced users are expressly prohibited of taking any action, unless explicitly requested by specialized technicians to do so.
- Installations must be frequently inspected for unbalance and the wear signals of the cables, springs, hinges, wheels, supports and other mechanical assembly parts.
- Do not use the product if it is necessary repair or adjustment is required.
- When performing maintenance, cleaning and replacement of parts, the product must be disconnected from power supply. Also including any operation that requires opening the product cover.
- The use, cleaning and maintenance of this product may be carried out by any persons aged eight years old and over and persons whose physical, sensorial or mental capacities are lower, or by persons without any knowledge of the product, provided that these are supervision and instructions given by persons with experienced in terms of usage of the product in a safe manner and who understands the risks and dangers involved.

- Children shouldn't play with the product or opening devices to avoid the motorized door or gate from being triggered involuntarily.

WARNINGS FOR TECHNICIANS

- Before beginning the installation procedures, make sure that you have all the devices and materials necessary to complete the installation of the product.
- You should note your Protection Index (IP) and operating temperature to ensure that is suitable for the installation site.
- Provide the manual of the product to the user and let them know how to handle it in an emergency.
- If the automatism is installed on a gate with a pedestrian door, a door locking mechanism must be installed while the gate is in motion.
- Do not install the product "upside down" or supported by elements do not support its weight. If necessary, add brackets at strategic points to ensure the safety of the automatism.
- Do not install the product in explosive site.
- Safety devices must protect the possible crushing, cutting, transport and danger areas of the motorized door or gate.
- Verify that the elements to be automated (gates, door, windows, blinds, etc.) are in perfect function, aligned and level. Also verify if the necessary mechanical stops are in the appropriate places.
- The central must be installed on a safe place of any fluid (rain, moisture, etc.), dust and pests.
- You must route the various electrical cables through protective tubes, to protect them against mechanical exertions, essentially on the power supply cable. Please note that all the cables must enter the central from the bottom.
- If the automatism is to be installed at a height of more than 2,5m from the ground or other level of access, the minimum safety and health requirements for the use of work equipment workers at the work of Directive 2009/104/CE of European Parliament and of the Council of 16 September 2009.

01. SAFETY INSTRUCTIONS

- Attach the permanent label for the manual release as close as possible to the release mechanism.
- Disconnect means, such as a switch or circuit breaker on the electrical panel, must be provided on the product's fixed power supply leads in accordance with the installation rules.
- If the product to be installed requires power supply of 230Vac or 110Vac, ensure that connection is to an electrical panel with ground connection.
- The product is only powered by low voltage safety with central (only at 24V motors)

WARNINGS FOR USERS

- Keep this manual in a safe place to be consulted whenever necessary.
- If the product has contact with fluids without being prepared, it must immediately disconnect from the power supply to avoid short circuits, and consult a specialized technician.
- Ensure that technician has provided you the product manual and informed you how to handle the product in an emergency.
- If the system requires any repair or modification, unlock the automatism, turn off the power and do not use it until all safety conditions have been met.
- In the event of tripping of circuits breakers or fuse failure, locate the malfunction and solve it before resetting the circuit breaker or replacing the fuse. If the malfunction is not repairable by consult this manual, contact a technician.
- Keep the operation area of the motorized gate free while the gate is in motion, and do not create strength to the gate movement.
- Do not perform any operation on mechanical elements or hinges if the product is in motion.

RESPONSABILITY

- Supplier disclaims any liability if:
 - Product failure or deformation result from improper installation use or maintenance!
 - Safety norms are not followed in the installation, use and maintenance of the product.
 - Instructions in this manual are not followed.
 - Damaged is caused by unauthorized modifications
 - In these cases, the warranty is voided.

MOTORLINE ELECTROCELOS SA.

Travessa do Sobreiro, nº29
4755-474 Rio Côvo (Santa Eugénia)
Barcelos, Portugal

SYMBOLS LEGEND:



• Important safety notices



• Useful information



• Programming information



• Connectors information

02. CHANGE MOTOR DIRECTION

CONNECTIONS SCHEME

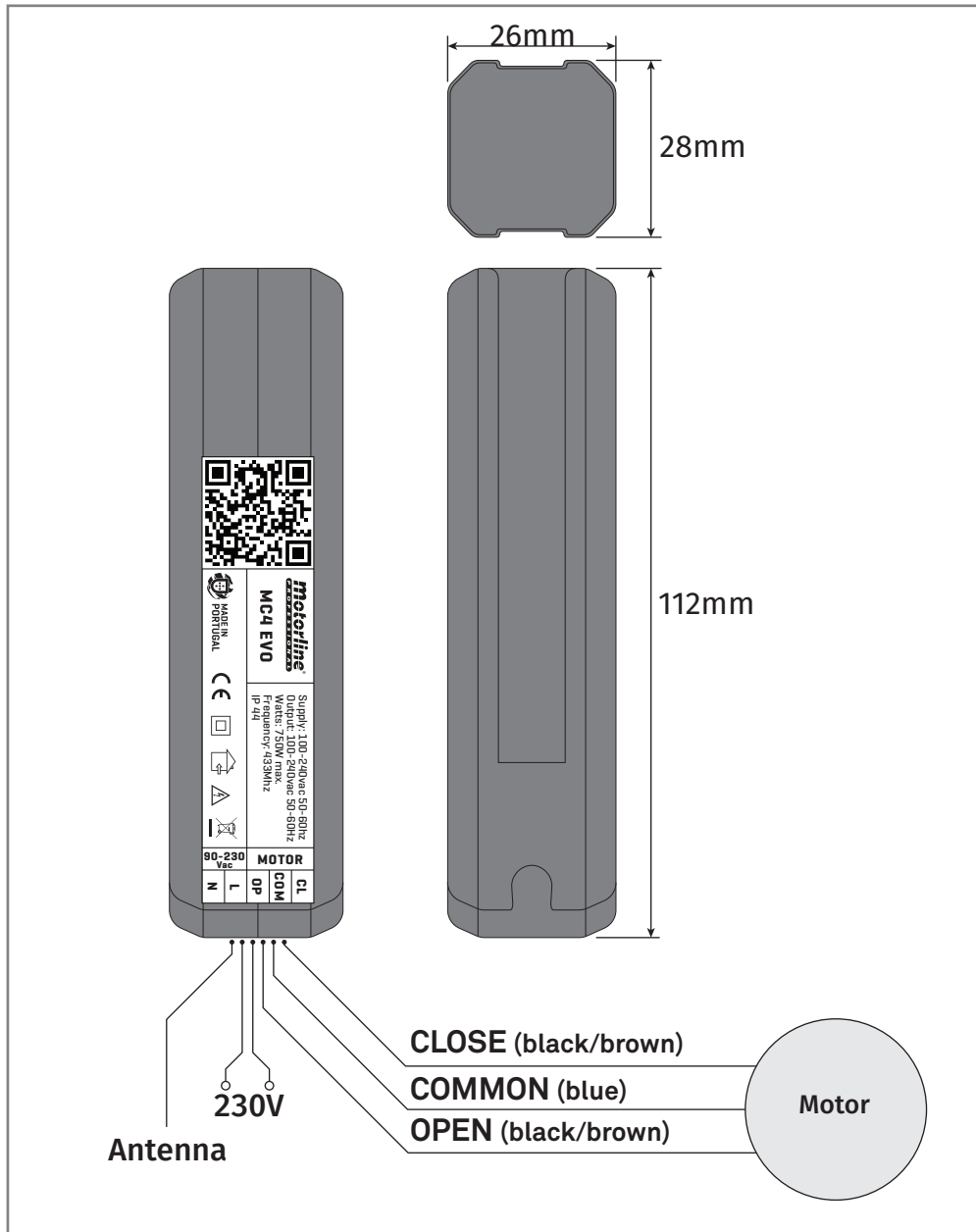

03. THE CONTROL BOARD

TECHNICAL CHARACTERISTICS

This control board was developed for rolling motors. (Shutters, rolling grilles, blinds, etc.) Works with 230V motors with built-in radio module. Its small size allows it to be installed in places with reduced space. It has screwless connectors in order to increase the speed and ease of connection.

• Power supply	100-230Vac 50-60Hz
• Motor output	230Vac; 750W Máx
• Built-in radio receiver	433,92 MHz
• Working temperature	-20°C to 70°C
• Number of channels	120 remote controls
• Code type	Rolling Code
• Protection range	IP44
• Fixed maximum working time per maneuver	4 min
• Box material	ABS

CONNECTORS DESCRIPTION

CM1	01 • 100-230Vac line input (neutral)
	02 • 100-230Vac line input (phase)
	03 • Motor output - OPENING
	04 • Motor output - COMMON
	05 • Motor output - CLOSING

04. PROGRAMMING

PRE-PROGRAMMING INFORMATION

• TYPE OF REMOTE CONTROL PROGRAMMING

The control board allows the programming of two operating modes in remote controls: 1 key or 3 keys.

1 KEY	You can program any key on the remote control, which will send all orders to the control board. Example: Open - Stop - Close - Stop - Open (...)
3 KEYS	The programmed command will work with the keys: OPEN CLOSE STOP Each key will send a different order to the control panel.

To know the **OPEN**, **STOP** and **CLOSE** keys of the various remote controls, check the following diagrams:

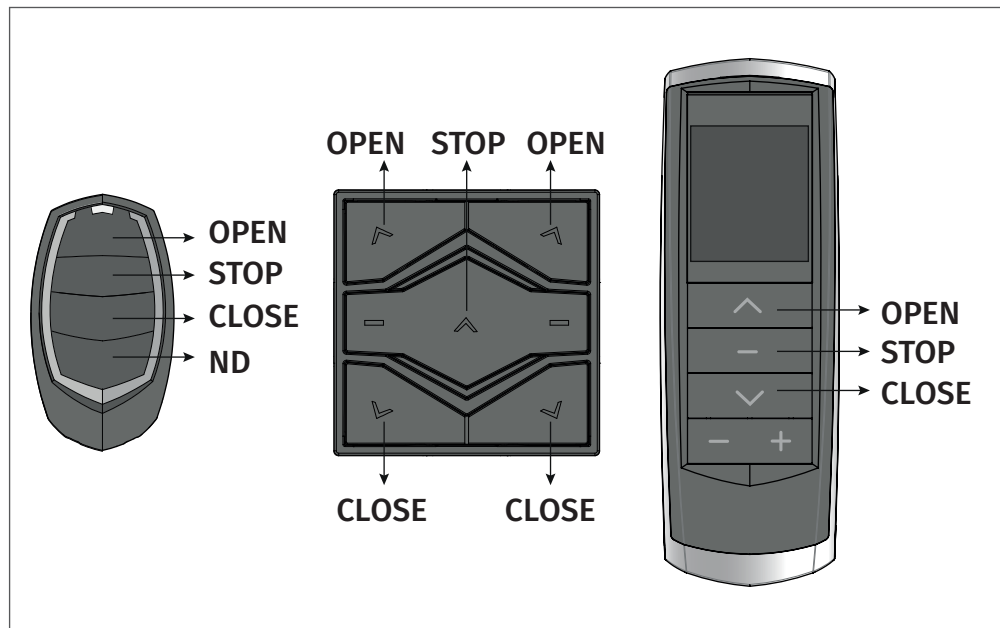

04. PROGRAMMING

REMOTE CONTROL PROGRAMMING

This control board only allows the programming of Rolling Code MOTORLINE remote controls up to a maximum of 120 remotes controls. When programming the 121st remote control, the control board emits 1 long beep to indicate that the memory is full.

To program the first command, you can do it through the control panel's power supply or through a panel. When you have a command already programmed, you can use it to open the control panel's memory remotely and program new commands.

Program new remote control (3 keys):

- 01** • Press and hold the **OPEN** key of the remote control you want to program.
- 02** • Connect the control board to a 100-230Vac power supply.
- 03** • Keep the **OPEN** key pressed for 10 seconds, during which the control board emits 5 slow beeps.
- 04** • After 10 seconds, the control board emits 3 quick beeps confirming the success of the programming. Release the remote control key to finish programming the 3 keys.
- 05** • If you want, you can add more remote controls for 10 seconds. If you press a remote control that has already been programmed, you will hear long, fast beeps.
- 06** • After 10 seconds without any activity, the programming exits, signaled by 3 beeps.

Program new remote control (1 key):

- 01** • Press and hold the **OPEN** key of the remote control you want to program.
- 02** • Connect the control board to a 100-230V power supply.
- 03** • Keep the **OPEN** key pressed for 10 seconds, during which the control board emits 5 slow beeps.
- 04** • After these 10 seconds, the control board emits 3 quick beeps.

04. PROGRAMMING

REMOTE CONTROL PROGRAMMING

- 05** • Keep the **OPEN** key pressed for another 6 seconds, during which the control board emits 3 slow beeps.
- 06** • After a total of 16 seconds (10+6), the control board emits 3 quick beeps confirming the success of the programming.
- 07** • If you want, you can add more remote controls for 10 seconds. If you press a remote control that has already been programmed, you will hear long, fast beeps.
- 08** • After 25 seconds without any activity, the programming exits, signaled by 3 beeps.

PROGRAMMING OF REMOTE CONTROLS THROUGH 1 ALREADY PROGRAMMED

Program a new remote control (3 keys) through another already programmed:

- 01** • Press and hold the **OPEN** key of an already programmed remote control for 15 seconds.
- 02** • After 15 seconds, the control board emits 5 quick beeps. Release the key of the remote control already programmed (if you continue to press the key, the control board will signal with long and fast beeps).
- 03** • Press and hold the **OPEN** key of the remote control you want to program.
- 04** • Keep the **OPEN** key pressed for 10 seconds, during which the control board emits 5 slow beeps.
- 05** • After 10 seconds, the control board emits 3 quick beeps confirming the success of the programming. Release the remote control key to finish programming the 3 keys.
- 06** • If you want, you can add more remote controls for 10 seconds. If you press a remote control that has already been programmed, you will hear long, fast beeps.
- 07** • After 10 seconds without any activity, the programming exits, signaled by 3 beeps.

04. PROGRAMMING

PROGRAMAÇÃO DE COMANDOS ATRAVÉS DE 1 JÁ PROGRAMADO

Program a new remote control (1 key) using another already programmed:

- 01** • Press and hold the **OPEN** key of an already programmed remote control for 15 seconds.
- 02** • After 15 seconds, the control board emits 5 quick beeps. Release the key of the remote control already programmed.
- 03** • Press and hold the **OPEN** key of the remote control you want to program.
- 04** • Keep the **OPEN** key pressed for 10 seconds during which the control board emits 5 slow beeps. After this time, the control board emits 2 quick beeps.
- 05** • Keep the **OPEN** key pressed for another 6 seconds, during which the control board emits 3 slow beeps.
- 06** • After a total of 16 seconds (10+6), the control board emits 3 quick beeps confirming the success of the programming.
- 07** • If you wish, you can add more remote controls for 10 seconds. If you press a remote control that has already been programmed, you will hear long, fast beeps.
- 08** • After 10 seconds without any activity, the programming exits, signaled by 3 beeps.



If the remote control already programmed has 3 keys, press the up key. If only one key, press the programmed key

04. PROGRAMMING

DELETE REMOTE CONTROLS

Delete all remote controls using a remote control already programmed:

- 01** • Press continuously the **OPEN** and **CLOSE** keys of an already programmed remote control.
- 02** • Connect the control board to a 100-230Vac power supply.
- 03** • Keep the **OPEN** and **CLOSE** keys pressed for 10 seconds, during which the control board emits 5 slow beeps.
- 04** • After 10 seconds, the control board emits 1 beep for 2 seconds confirming the success of the programming.

CHANGE MOTOR DIRECTION

- 01** • Press and hold the **CLOSE** key of an already programmed remote control.
- 02** • Connect the control board to a 100-230Vac power supply.
- 03** • Keep the **CLOSE** key pressed for 10 seconds, during which the control board emits 5 slow beeps.
- 04** • After 10 seconds, the control board emits 1 long beep for 2 seconds confirming the success of the programming.