



WIWEATHER

USER'S AND INSTALLER'S MANUAL



EN

3.0 REV/08/2020





00. CONTENT

INDEX

01. SAFETY INSTRUCTIONS	1B
02. INSTALLATION	4B
03. INITIAL FUNCTIONING CONDITION	5A
04. WIND SENSOR FUNCTIONING	5A
05. SUN SENSOR FUNCTIONING	5A
06. RAIN SENSOR FUNCTIONING	5A
07. PROGRAMMING KEYS AND INDICATOR LED	
SEL KEY	5B
SET KEY	5B
INDICATOR LED	5B
CODE - SEND COMMAND SIGNAL	5B
SPEED - CHECK PROGRAMMED WIND LIMIT	6A
SPEED - SET WIND LIMITS BETWEEN 5 AND 40KM/H	6A
WIND - WIND SENSOR ON/OFF	6A
SUN - SUN SENSOR ON/OFF	6A
RAIN - RAIN SENSOR ON/OFF	6A
08. SENSOR MONITORING LEDS	
TEST - ON/OFF SENSORS TEST	6B
TEST - RUN TEST TO WIND SENSOR (ANEMOMETER)	6B
TEST - RUN TEST TO SUN SENSOR	6B
TEST - RUN TEST TO RAIN SENSOR	6B

01. SAFETY INSTRUCTIONS

ATTENTION:

	This product is certified in accordance with European Community (EC) safety standards.
	This product complies with Directive 2011/65/EU of the European Parliament and of the Council, of 8 June 2011, on the restriction of the use of certain hazardous substances in electrical and electronic equipment.
	(Applicable in countries with recycling systems). This marking on the product or literature indicates that the product and electronic accessories (eg. Charger, USB cable, electronic material, controls, etc.) should not be disposed of as other household waste at the end of its useful life. To avoid possible harm to the environment or human health resulting from the uncontrolled disposal of waste, separate these items from other types of waste and recycle them responsibly to promote the sustainable reuse of material resources. Home users should contact the dealer where they purchased this product or the National Environment Agency for details on where and how they can take these items for environmentally safe recycling. Business users should contact their vendor and check the terms and conditions of the purchase agreement. This product and its electronic accessories should not be mixed with other commercial waste.
	
	This marking indicates that the product and electronic accessories (eg. charger, USB cable, electronic material, controls, etc.) are susceptible to electric shock by direct or indirect contact with electricity. Be cautious when handling the product and observe all safety procedures in this manual.

01. SAFETY INSTRUCTIONS

GENERAL WARNINGS

- This manual contains very important safety and usage information. very important. Read all instructions carefully before beginning the installation/usage procedures and keep this manual in a safe place that it can be consulted whenever necessary.
- This product is intended for use only as described in this manual. Any other enforcement or operation that is not mentioned is expressly prohibited, as it may damage the product and put people at risk causing serious injuries.
- This manual is intended firstly for specialized technicians, and does not invalidate the user's responsibility to read the "User Norms" section in order to ensure the correct functioning of the product.
- The installation and repair of this product may be done by qualified and specialized technicians, to assure every procedure are carried out in accordance with applicable rules and norms. Nonprofessional and inexperienced users are expressly prohibited of taking any action, unless explicitly requested by specialized technicians to do so.
- Installations must be frequently inspected for unbalance and the wear signals of the cables, springs, hinges, wheels, supports and other mechanical assembly parts.
- Do not use the product if it is necessary repair or adjustment is required.
- When performing maintenance, cleaning and replacement of parts, the product must be disconnected from power supply. Also including any operation that requires opening the product cover.
- The use, cleaning and maintenance of this product may be carried out by any persons aged eight years old and over and persons whose physical, sensorial or mental capacities are lower, or by persons without any knowledge of the product, provided that these are supervision and instructions given by persons with experienced in terms of usage of the product in a safe manner and who understands the risks and dangers involved.

- Children shouldn't play with the product or opening devices to avoid the motorized door or gate from being triggered involuntarily.

WARNINGS FOR TECHNICIANS

- Before beginning the installation procedures, make sure that you have all the devices and materials necessary to complete the installation of the product.
- You should note your Protection Index (IP) and operating temperature to ensure that is suitable for the installation site.
- Provide the manual of the product to the user and let them know how to handle it in an emergency.
- If the automatism is installed on a gate with a pedestrian door, a door locking mechanism must be installed while the gate is in motion.
- Do not install the product "upside down" or supported by elements do not support its weight. If necessary, add brackets at strategic points to ensure the safety of the automatism.
- Do not install the product in explosive site.
- Safety devices must protect the possible crushing, cutting, transport and danger areas of the motorized door or gate.
- Verify that the elements to be automated (gates, door, windows, blinds, etc.) are in perfect function, aligned and level. Also verify if the necessary mechanical stops are in the appropriate places.
- The central must be installed on a safe place of any fluid (rain, moisture, etc.), dust and pests.
- You must route the various electrical cables through protective tubes, to protect them against mechanical exertions, essentially on the power supply cable. Please note that all the cables must enter the central from the bottom.
- If the automatism is to be installed at a height of more than 2,5m from the ground or other level of access, the minimum safety and health requirements for the use of work equipment workers at the work of Directive 2009/104/CE of European Parliament and of the Council of 16

01. SAFETY INSTRUCTIONS

September 2009.

- Attach the permanent label for the manual release as close as possible to the release mechanism.
- Disconnect means, such as a switch or circuit breaker on the electrical panel, must be provided on the product's fixed power supply leads in accordance with the installation rules.
- If the product to be installed requires power supply of 230Vac or 110Vac, ensure that connection is to an electrical panel with ground connection.
- The product is only powered by low voltage safety with central (only at 24V motors)

WARNINGS FOR USERS

- Keep this manual in a safe place to be consulted whenever necessary.
- If the product has contact with fluids without being prepared, it must immediately disconnect from the power supply to avoid short circuits, and consult a specialized technician.
- Ensure that technician has provided you the product manual and informed you how to handle the product in an emergency.
- If the system requires any repair or modification, unlock the automatism, turn off the power and do not use it until all safety conditions have been met.
- In the event of tripping of circuits breakers or fuse failure, locate the malfunction and solve it before resetting the circuit breaker or replacing the fuse. If the malfunction is not repairable by consult this manual, contact a technician.
- Keep the operation area of the motorized gate free while the gate in in motion, and do not create strength to the gate movement.
- Do not perform any operation on mechanical elements or hinges if the product is in motion.

RESPONSABILITY

- Supplier disclaims any liability if:
 - Product failure or deformation result from improper installation use or maintenance!
 - Safety norms are not followed in the installation, use and maintenance of the product.
 - Instructions in this manual are not followed.
 - Damaged is caused by unauthorized modifications
 - In these cases, the warranty is voided.

SYMBOLS LEGEND:



• Important safety notices



• Useful information



• Programming information



• Potentiometer information



• Connectors information



• Buttons information



All operations requiring the opening of the device (cable connections, programming, etc.) must only be carried out by specialized technicians during the installation or programming! For any subsequent operation that requires the device to be opened again, contact your technical assistance.



If this device is purchased together with an MOTORLINE awning, it is already factory programmed. In this case, you only need to adjust the wind and brightness limit according to your preference.

The technical characteristics are as follows:

	WIWEATHER
• Power Supply	230V 50/60Hz 3W máx.
• Working temperature	-10 ~55°C
• Anemometer Sensitivity	5 ÷ 40 Km/h
• Sun Sensor Sensitivity	5 ÷ 40 Klux
• IP	IP54
• Frequency	433,92 Hz



If this device sends an order to execute a safety close by activating the rain or wind sensor, it is only possible to reopen the awning after 15 minutes.

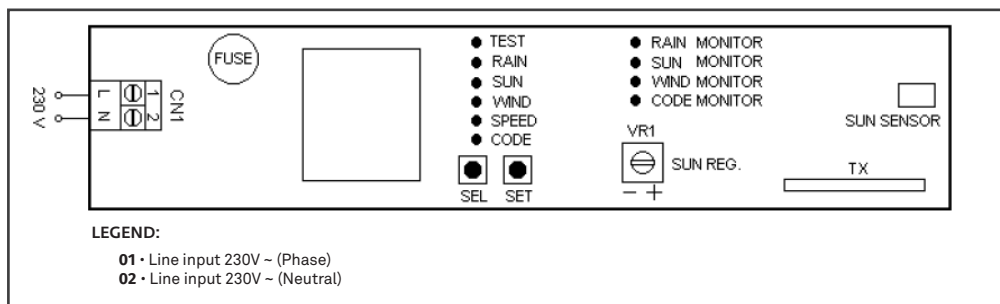

02. INSTALLATION

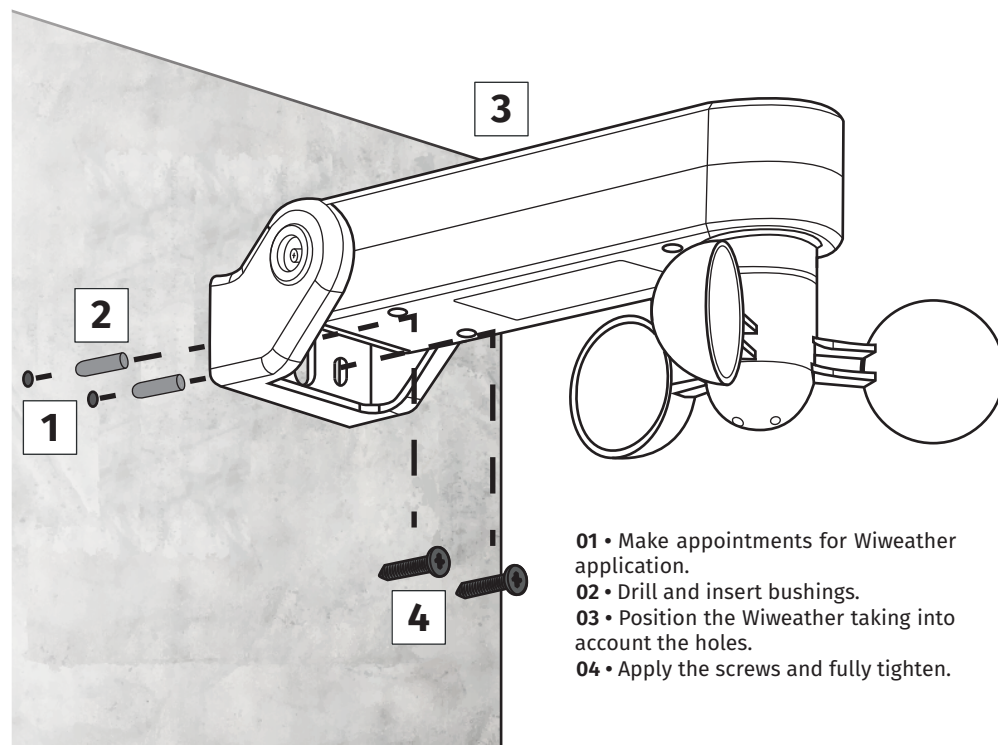

Wiweather must be installed in the position indicated in the installation drawing. If you do not respect this indication, it may jeopardize the normal functioning of the product.

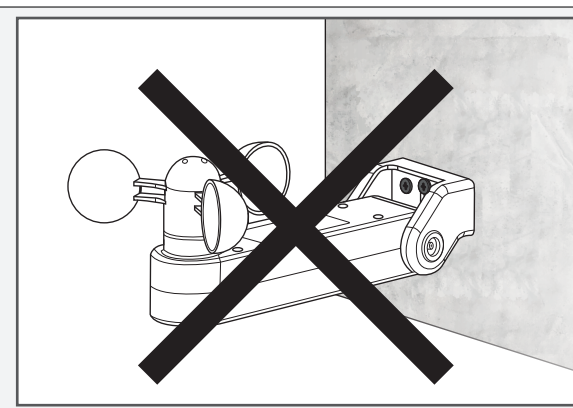

03. INITIAL FUNCTIONING CONDITION

- This device can be connected to one or more Rolling Code compatible MOTORLINE centrals to receive sensor status information. For this operation, you have to program the Wireless Sensor in the central to which it is to be connected.

04. WIND SENSOR FUNCTIONING

- The sensor will send a closing order to the central to which it is connected, whenever the wind threshold is exceeded.

05. SUN SENSOR FUNCTIONING

- The sensor sends an opening order to the central to which it is connected, after 10 minutes of brightness higher to the threshold selected on the potentiometer VR1, displayed through the SUN MONITOR LED. The sensor send a closing order after 10 minutes with brightness below the select limit.

REGULATION OF SENSITIVITY TO THE SUN (5 ÷ 40 KLUX)

- The sensor allows to adjust the brightness limit using the potentiometer VR1. The switching on of the SUN MONITOR LED on the device indicates that the Sun intensity exceeds the selected intervention threshold. In this way, you can use this signal as a reference to set the limit for the current brightness.



In this case the sensor should be installed so that the brightness is uniform throughout the day.

06. RAIN SENSOR FUNCTIONING

- The sensor sends a closing order as soon as the sensitive part of the sensor is wet by water. This order is signaled by the RAIN MONITOR LED.

07. PROGRAMMING KEYS AND INDICATOR LED

SEL KEY

- Allows you to select a function to change it by pressing the key until the flashing of the LED. The selection remains active for 15 seconds, displayed by the flashing LED, after which time it goes to stand-by.

SET KEY

- Carries out the programming of the function chosen with the SEL key.

INDICATOR LED

- **LED on:** memorized option.
- **LED off:** option not memorized.
- **Flashing LED:** option selected.

LED	OFF	ON
CODE	Code sending = OFF	Code sending = ON
SPEED	Wind Safety 25 km/h	Pgm. Wind Safety
WIND	Wind Safety = OFF	Wind Safety = ON
SUN	Sun Safety = OFF	Sun Safety = ON
RAIN	Rain Safety = OFF	Rain Safety = ON
TEST	Test Function = OFF	Test Function =ON



As soon as the WiWeather is configured on the central, it **must be** connected to a power supply and kept within the range of the central! Otherwise, the central can not detect the sensor and enters in the safe mode, not allowing the awning to be opened.

CODE - SEND COMMAND SIGNAL

- The device must be connected to the central as follows:
01 • On the central, activate the command signal configuration function (see the technical manual of the central)
02 • Press the SEL key as many times as necessary until the CODE LED starts blinking.
03 • Press the SET key for 1 to 2 seconds.
At this time, the sensor will send a code to the central, signaled by the CODE MONITOR LED.



You should check the connected central if there is any confirmation that the sensor is programmed (see the central manual).
The sensor will send command signals depending on weather conditions.
Repeat the above operations if you wish to program the same sensor in other compatible centrals.

SPEED - CHECK PROGRAMMED WIND LIMIT

• To refer to the Set Wind Limit, follow these instructions:

- 01 • Press the SEL key as many times as necessary until the SPEED LED starts blinking. The SPEED LED will show the wind limit defined by one or more double flashes, each of which equals 5Km / h (example: 3 double flashes equals 15Km / h)

SPEED - SET WIND LIMITS BETWEEN 5 AND 40KM/H

• The sensor is supplied with the safety limit for wind equal to 25Km/h (SPEED LED OFF).

To change the safety limit for wind, follow these steps:

- 01 • Press the SEL key as many times as necessary until the SPEED LED starts blinking.
- 02 • Press the SET key to enter programming mode.
- 03 • At the same time, the SPEED LED will blink in double flashes, each of which equals an increase of 5Km/h.
- 04 • Press the SET key when the SPEED LED flashes as many times as necessary to memorize this option (example: 4 double flashes equals 20Km/h). The SPEED LED will be ON to confirm the success of the operation.

WIND - WIND SENSOR ON/OFF

• The device comes with the wind sensor switched on (WIND LED ON).

To change this setting, follow these steps:

- 01 • Press the SEL key as many times as necessary until the WIND LED starts blinking.
- 02 • Press the SET key to change the status of the WIND LED.

SUN - SUN SENSOR ON/OFF

• The device is supplied with the sun sensor switched off (LED SUN OFF).

To change this setting, follow these steps:

- 01 • Press the SEL key as many times as necessary until the SUN LED starts blinking.
- 02 • Press the SET key to change the status of the SUN LED.

RAIN - RAIN SENSOR ON/OFF

• The device comes with the wind sensor switched on (RAIN LED ON).

To change this setting, follow these steps:

- 01 • Press the SEL key as many times as necessary until the RAIN LED starts blinking.
- 02 • Press the SET key to change the status of the RAIN LED.



RESET

To return to the factory settings, press the SEL and SET keys simultaneously until all the LEDs are lit at the same time. The LEDs will turn off immediately, signaling the success of the operation.

08. SENSOR MONITORING LEDS

• This device has 4 MONITOR signaling LEDs, to test whether the device sends closing or opening orders to the programmed centrals corresponding to each sensor.

LED	OFF	ON
CODE MONITOR	Signal= OFF	Send signal to the central
WIND MONITOR	Wind below the limit	Wind above the limit
SUN MONITOR	Brightness below the limit	Brightness above the limit
RAIN MONITOR	Dry rain sensor	Wet rain sensor

TEST - ON/OFF SENSORS TEST

• The device is supplied with the wind, sun and rain sensors test off (LED TEST OFF).

To change this setting, follow these steps:

- 01 • Press the SEL key as many times as necessary until the TEST LED starts blinking.
- 02 • Press the SET key to change the status of the TEST LED.



When you are finished testing the sensors, you must **turn off** the Test mode so that the device can function normally.

TEST - RUN TEST TO WIND SENSOR (ANEMOMETER)

01 • Manually turn the anemometer blades.

The WIND MONITOR LED will turn on, signaling the closing order sending to the central, for 5 seconds.

TEST - RUN TEST TO SUN SENSOR

01 • Turn the potentiometer VR1 clockwise (towards the + side), and at the same time, SUN MONITOR LED will turn on, signaling the order of opening to the central for 5 seconds.

02 • Turn the potentiometer VR1 counterclockwise (towards the - side), and at the same time, SUN MONITOR LED will turn off, signaling the closing order sending to the central for 5 seconds.

TEST - RUN TEST TO RAIN SENSOR

01 • Lightly wet the rain sensor zone, and at the same time, RAIN MONITOR LED will turn on, signaling the order of closing order to the central, for 5 seconds.

After completed the test, ensure to have dried the rain sensor zone before using the central in the normal functioning.