



SCMV150





EN

v1.0
REV.06/2018

INSTALLER AND USER'S MANUAL



CE	This product is certified in accordance with European Community (EC) safety standards.
RoHS	This product complies with Directive 2011/65/EU of the European Parliament and of the Council, of 8 June 2011, on the restriction of the use of certain hazardous substances in electrical and electronic equipment.
 	(Applicable in countries with recycling systems). This marking on the product or literature indicates that the product and electronic accessories (eg. Charger, USB cable, electronic material, controls, etc.) should not be disposed of as other household waste at the end of its useful life. To avoid possible harm to the environment or human health resulting from the uncontrolled disposal of waste, separate these items from other types of waste and recycle them responsibly to promote the sustainable reuse of material resources. Home users should contact the dealer where they purchased this product or the National Environment Agency for details on where and how they can take these items for environmentally safe recycling. Business users should contact their vendor and check the terms and conditions of the purchase agreement. This product and its electronic accessories should not be mixed with other commercial waste.
	This marking indicates that the product and electronic accessories (eg. charger, USB cable, electronic material, controls, etc.) are susceptible to electric shock by direct or indirect contact with electricity. Be cautious when handling the product and observe all safety procedures in this manual.

and will void the warranty.

- Do not make any changes to the automation components and/or their accessories.
- The customer shall not, under any circumstances, attempt to repair or tune the automatism. Must call qualified technician only.
- The installer must have certified professional knowledge at the level of mechanical assemblies in doors and gates and control board programming. He should also be able to perform electrical connections in compliance with all applicable regulations.
- The installer should inform the customer how to handle the product in an emergency and provide him the manual.
- This device can be used by children 8 year old or older and persons whose physical, sensory or mental capacities are reduced, or by persons without experience or knowledge if they have received supervision or instructions on the use of the device in a safe manner and understood the hazards involved. Children should not play with the device. Cleaning and maintenance by the user must not be carried out by unsupervised children.
- Before installing, the installer must verify that the temperature range indicated on the automatism is appropriate to the location of the installation.

- It is important for your safety that these instructions are followed.
- Keep these instructions in a safe place for future reference.
- The **ELECTROCELOS S.A.** is not responsible for the improper use of the product, or other use than that for which it was designed.
- The **ELECTROCELOS S.A.** is not responsible if safety standards were not taken into account when installing the equipment, or for any deformation that may occur.
- The **ELECTROCELOS S.A.** is not responsible for insecurity and malfunction of the product when used with components that were not sold by the them.
- This product was designed and manufactured strictly for the use indicated in this manual.
- Any other use not expressly indicated may damage the product and/or can cause physical and property damages,

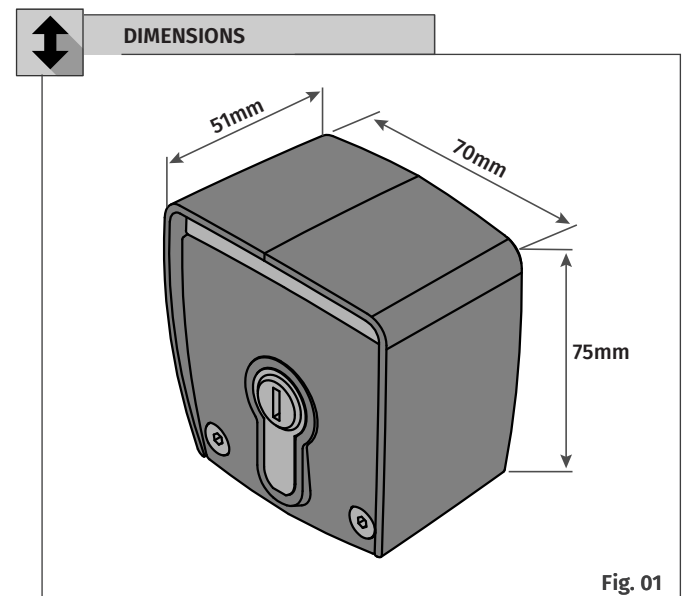



INSTALLATION

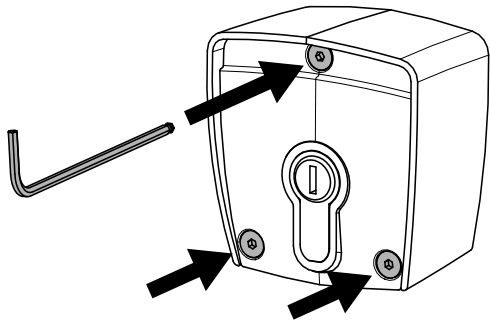

Fig. 02

1 • Loosen the 3 screws of the cover plate.

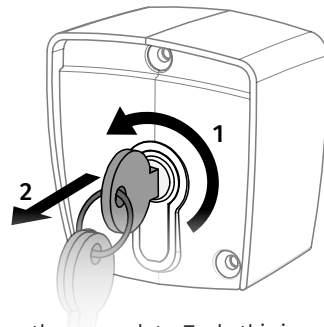

Fig. 03

2 • Remove the cover plate. To do this insert the key, turn it to the left and pull out.

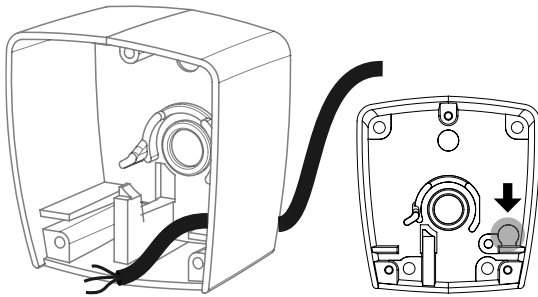

Fig. 04

3 • Pass the wires into the box through the hole indicated in the figure.

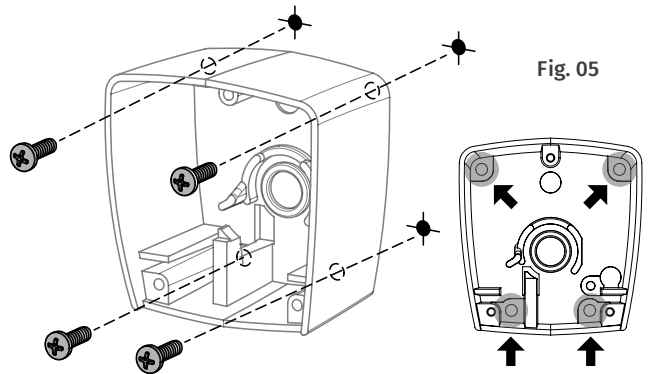

Fig. 05

4 • Attach the base of the box to the wall with 4 screws and using the holes in the base, shown in the figure.

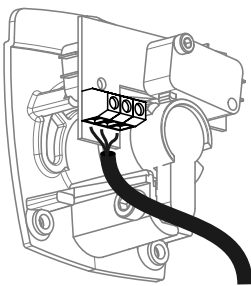

Fig. 06

5 • Connect the microswitches on the cover plate as in figure 10.

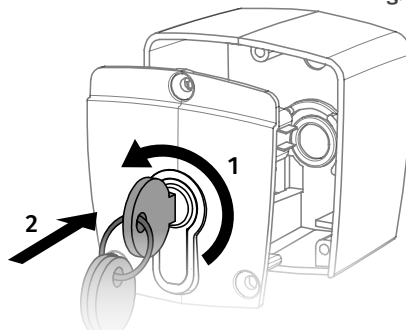

Fig. 07

6 • Replace the cover plate. To do this, turn the key to the left, insert the cover plate and release the key. Tighten the 3 screws with the indicated wrench.

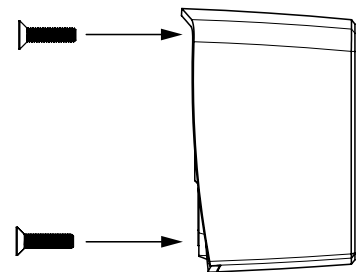

Fig. 08

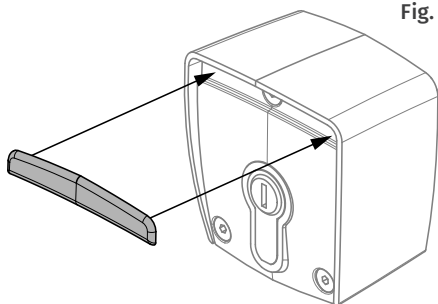

Fig. 09

7 • Place the **Motorline** label in the location shown in the figure.

• CONNECTING THE SWITCH TO THE CONTROL BOARD (SCMV150)

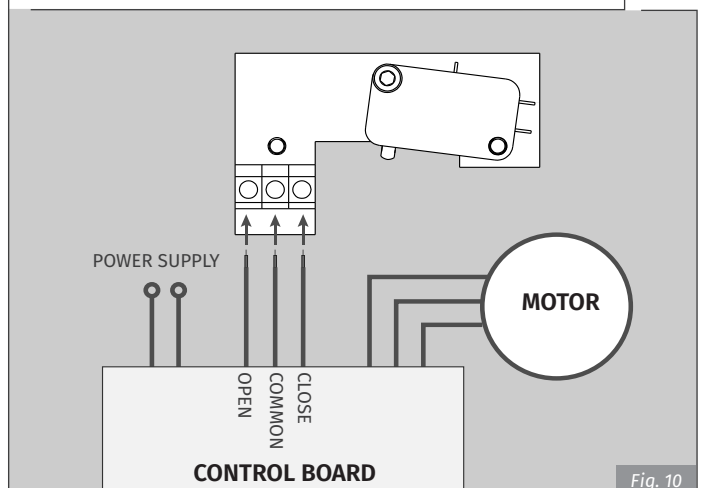

Fig. 10